

CABLE RAMPS-SAFETY-CABLE MANAGEMENT-PORTABLE-WIRE ORGANIZATION-CONDUIT

# DEFENDER

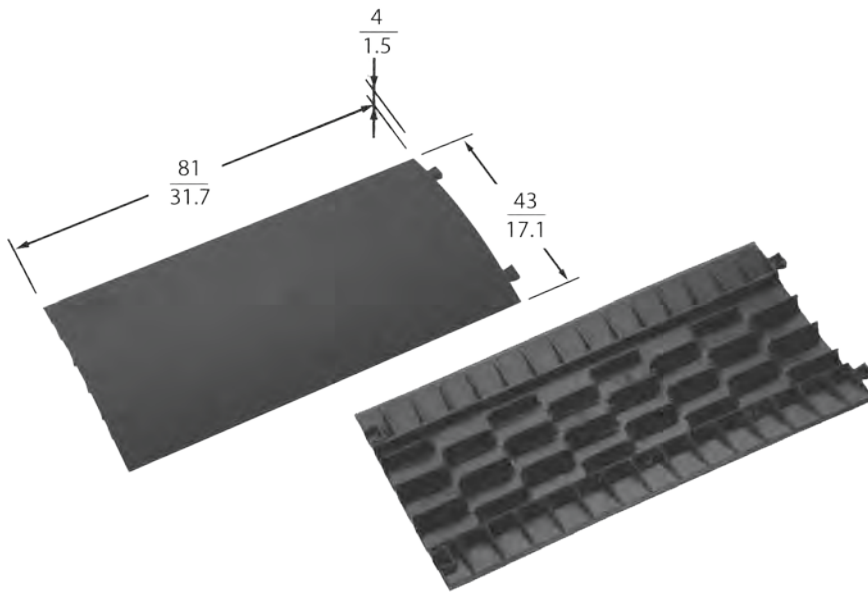
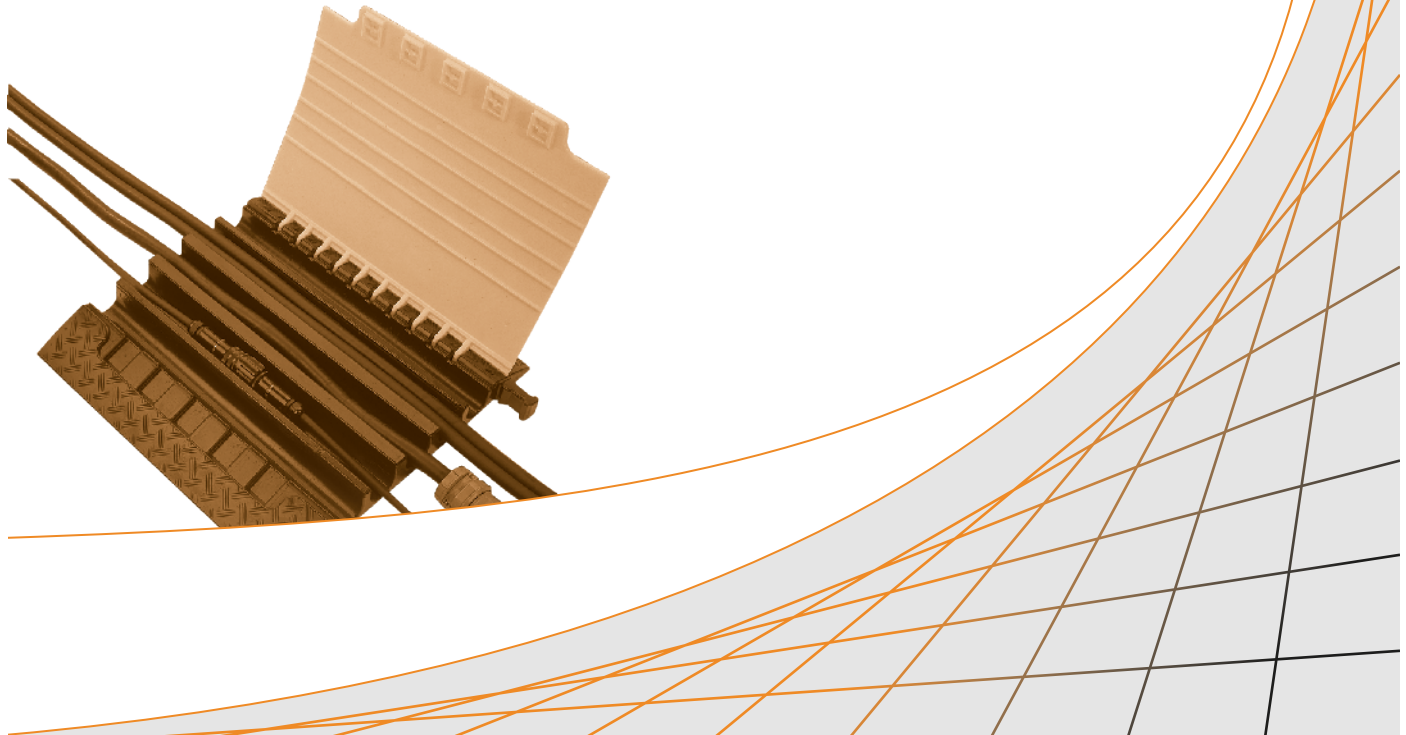

## 514-85100

### Defender Compact

Mat: Polyurethane | Finish: Black | Wt: 3.5kg / 7.7lbs

- Suitable for cable protection from foot traffic both indoors and outdoors, 300lb capacity
- Not suitable for vehicle traffic.
- Arrangement of supports molded into the bottom allows Defender Compact to be laid over a run of cables.
- 7 cable ducts measuring approximately 1.1" or 29mm.
- Anti-slip ribbed surface.

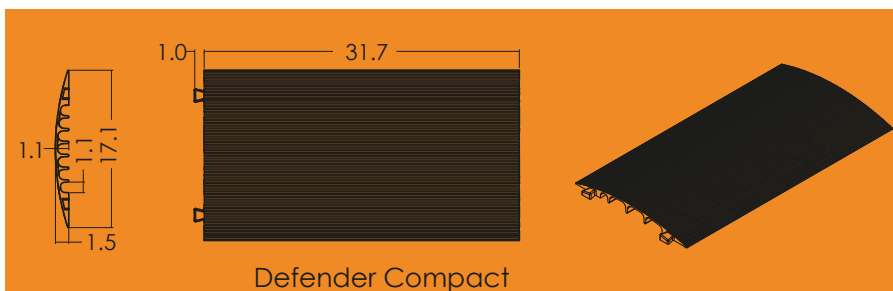

Defender Compact

## 514-85300

### Defender MIDI Cable Crossover

Mat: Polyurethane | Finish: Black/Yellow |  
Wt: .11.8kg / 25lbs

- Virtually indestructible Polyurethane body and lid, with high resistance to tearing.
- Improved elasticity for better grip on the underside of the unit.
- High load capacity for superior protection against large vehicle crossing, 11,200lbs (5 ton) capacity.
- Hinged lid with interlocking feature holds the lid open while laying in cables, and closed while in use.
- 5 cable ducts measuring approximately 1.33" or 34mm.
- Features hidden molded connectors.

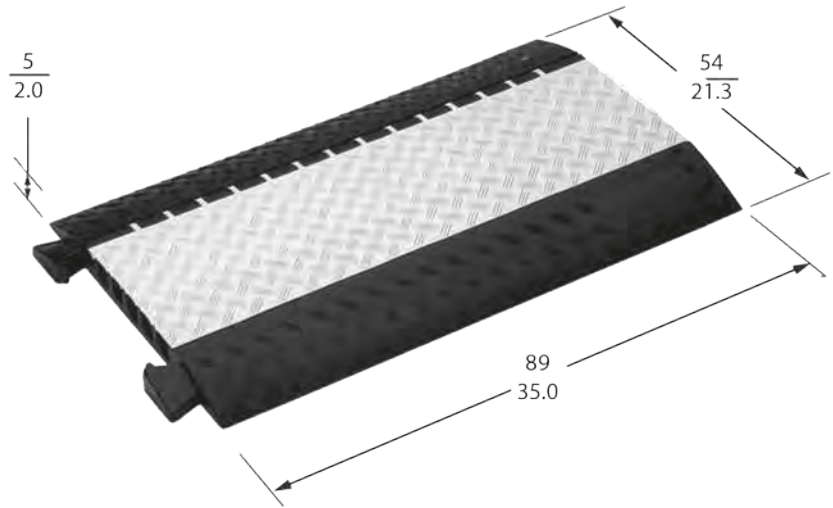

## 514-85310

### Defender MIDI 45 Degree Corner

Mat: Polyurethane | Finish: Black/Yellow |  
Wt: 3.18kg / 7.00lbs

- Allows Defender MIDI to negotiate 45 degree corners without leaving any exposed sections of cable.
- Each 45 degree angle supplied with 2 connector plugs.

514-85310

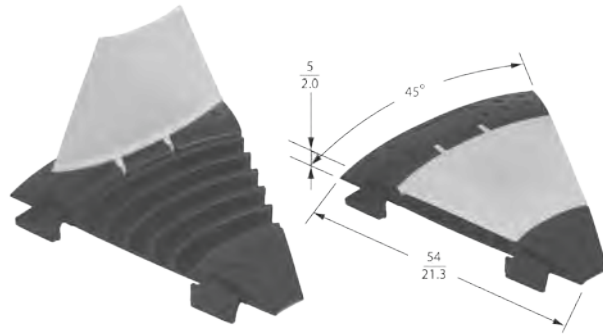

## 514-85308

### Defender MIDI End Ramp

Mat: Polyurethane | Finish: Black Wt: 1.04kg / 2.30lbs

- Protects cables from being kinked.
- Reduces hazard of tripping.
- Each end ramp supplied with 2 connector plugs.

514-85308

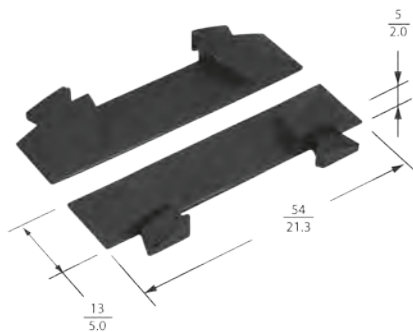

514-85311

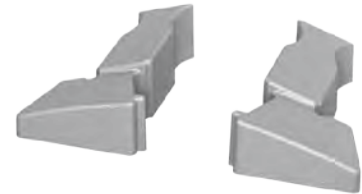

## 514-85311

### Defender MIDI Adapter

Mat: Polyurethane | Finish: Yellow | Wt: 0.7kg / 1.7lbs

- Inter-connect with competitive cable ramps.
- Sold as a pair, 1 right and 1 left
- Aligns cable channels between Defender MIDI and other ramps.

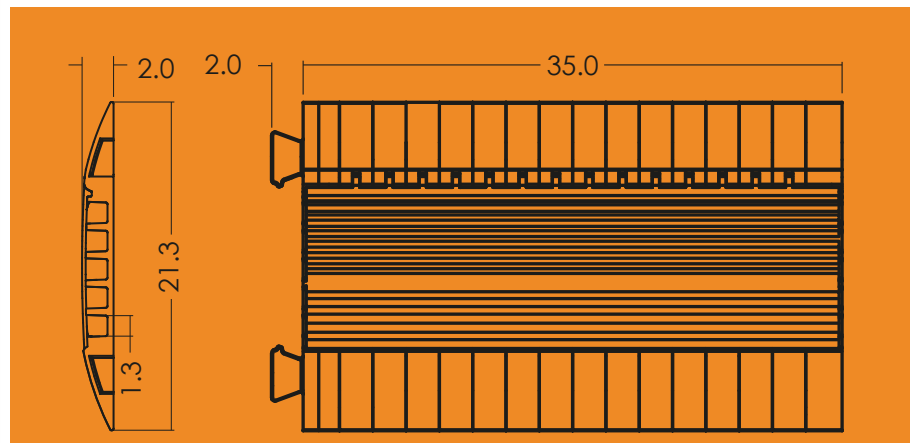

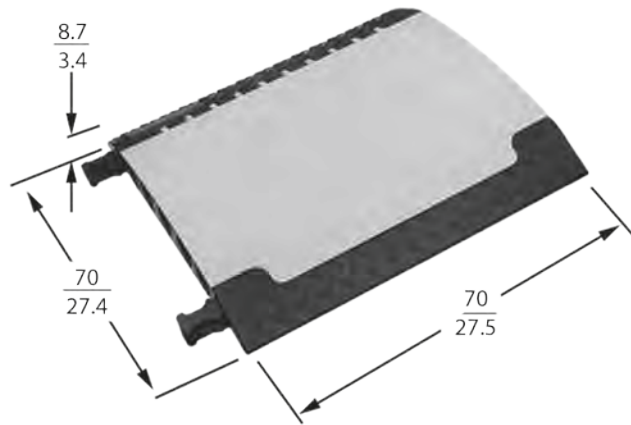

## 514-85500

### Defender XXL Cable Crossover

Mat: Polyurethane | Finish: Black/Yellow |  
Wt: 21.32kg / 47.00lbs

- 5 cable ducts with a 2 3/8" width.
- 3 channels with 2 3/8" diameter suitable for use with most fire department hoses.
- 6 ton load capacity.
- Optimum protection for power cables.

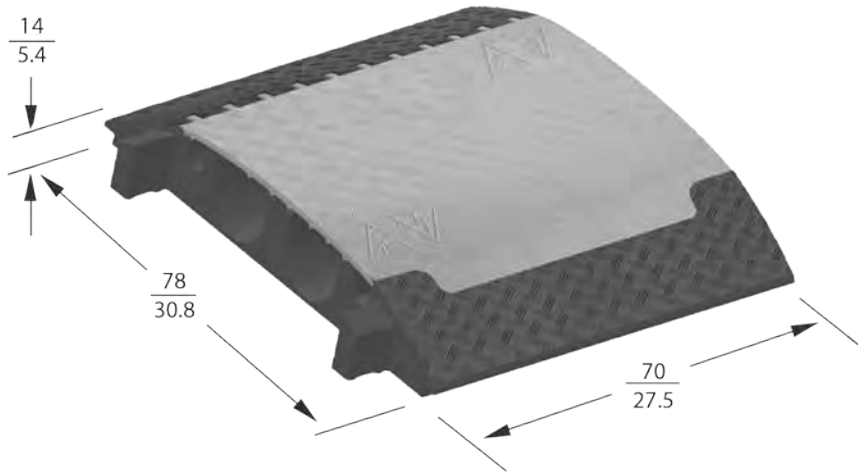
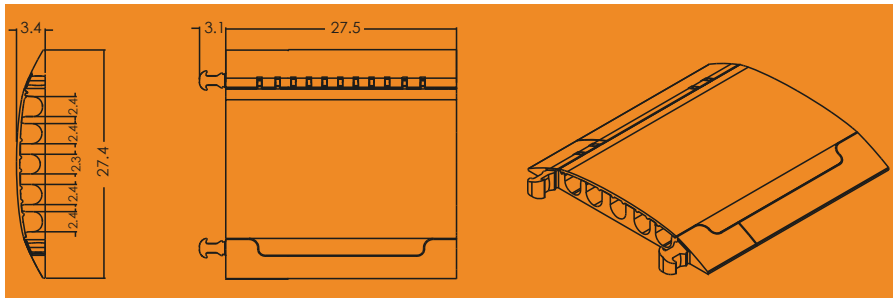

## 514-85600

### Defender Ultra L

Mat: Polyurethane | Finish: Black/Yellow |  
Wt: 30.50kg / 67.30lbs

- Developed in collaboration with suppliers for major events.
- 2 oversized cable/hose channels for lines up to 4".
- For fragile connections and connector housings not exceeding 3".
- 6 ton load capacity.

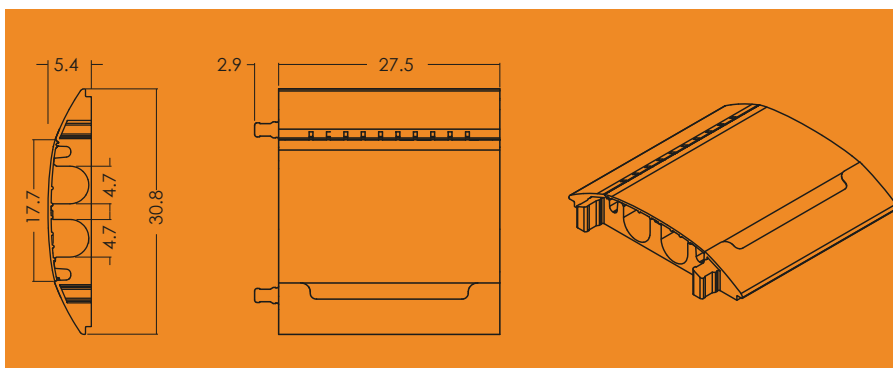

## 514-85002

### Defender III

Mat: Polyurethane | Finish: Black/Yellow |  
Wt: 19.00kg / 41.90lbs

- Maximum duty cable crossover with load bearing capacity of 11,000lbs.
- 3 large cable ducts measuring 2" x 2-3/16" (50mm x 56mm).
- Patented interlocking hinged lid for easy loading and unloading. Lid locks in place.
- Virtually indestructible polyurethane body and lid have high resistance to tearing.
- Each crossover has screw-in removable plugs.
- This is a special order item.

