

BACK RAIL-BLANK PANELS-SLOT PANELS-PRE PUNCHED-RACK SHELVES-DRAWERS-ACCESSORIES

RACK HARDWARE

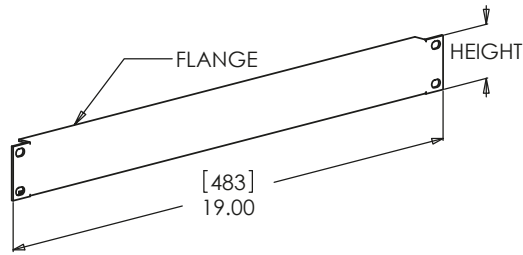
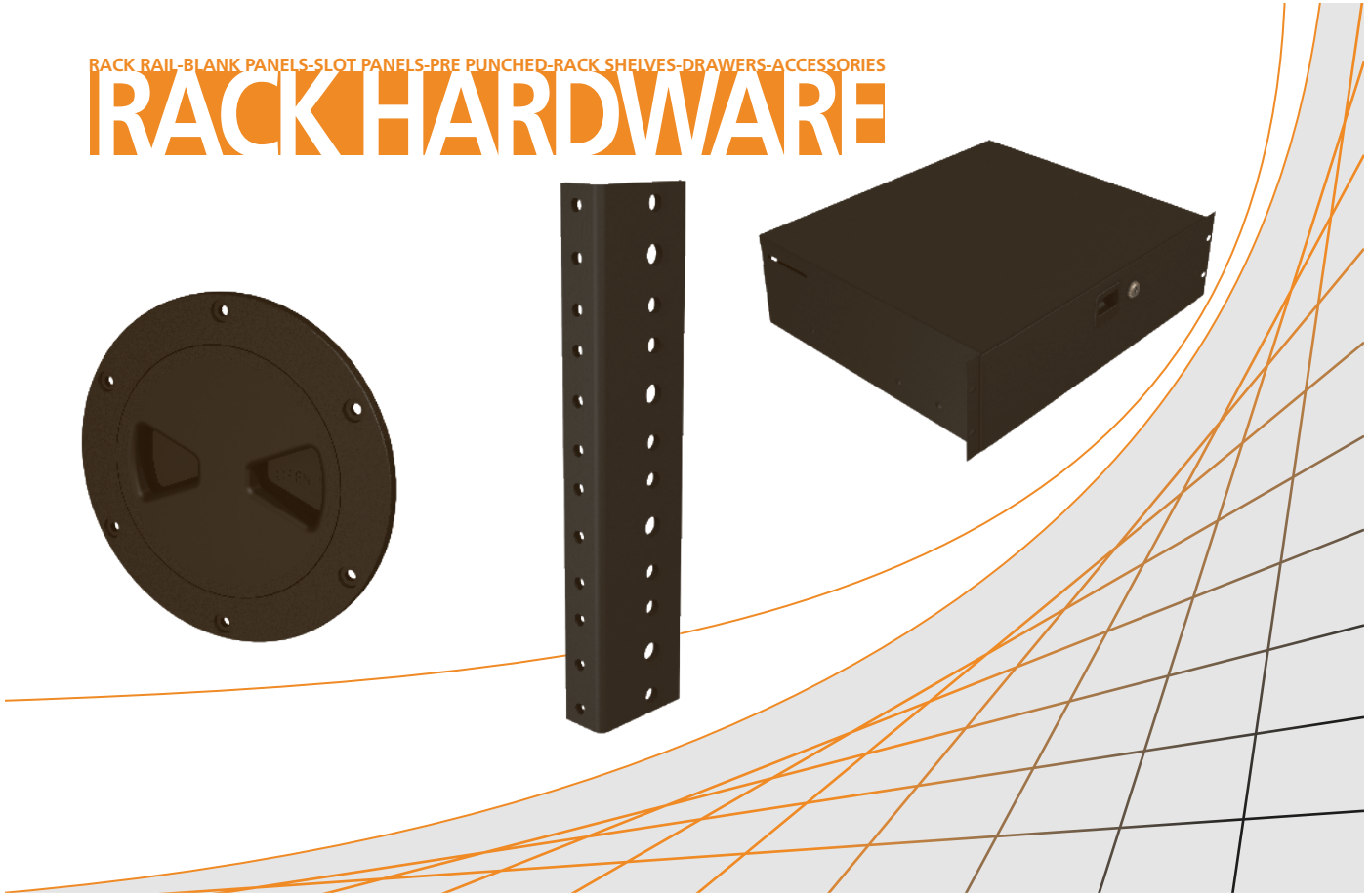

506-8701900

1 Space Blank Rack Panel

Mat: Steel | Finish: Black | Wt: .32kg / .71lbs

506-8702900

2 Space Blank Rack Panel

Mat: Steel | Finish: Black | Wt: .56kg / 1.23lbs

506-8703900

3 Space Blank Rack Panel

Mat: Steel | Finish: Black | Wt: .88kg / 1.94lbs

506-8704900

4 Space Blank Rack Panel

Mat: Steel | Finish: Black | Wt: 1.05kg / 2.31lbs

- Blank (unquenched) for making custom panels and patch bays or filling empty spaces in the rack.
- Pre-punched with four slots for mounting to rack.
- Standard rack width (483mm/19").
- Durable black textured finish resists marks and scratches.
- Made from heavy duty steel (1.5mm/16ga).
- Available in four sizes to fit one, two, three, or four rack spaces.
- 11mm/.43" flanges on top and bottom for extra strength.

12

13

14

15

16

17

18

19

506-8717900

Pre-Punched XLR Combination Jack Panel

Mat: Steel | Finish: Black | Wt: .27kg / .60lbs

- Pre-punched steel jack panel.
- 6 male and 6 female XLR combination configuration.
- Made from heavy duty steel (1.5mm/16ga).
- Standard rack width (483mm/19"). Fits single rack space (44.5mm/1.75")
- 11mm/.43" flanges on top and bottom for extra strength.
- Durable black textured finish resists marks and scratches.

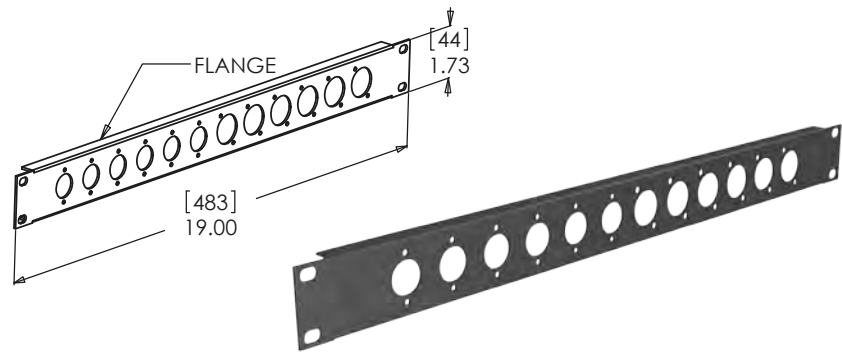

506-8716900

Pre-Punched Neutrik D Jack Panel

Mat: Steel | Finish: Black | Wt: .27kg / .60lbs

- Pre-punched steel jack panel.
- 12 Neutrik Series "D".
- Made from heavy duty steel (1.5mm/16ga).
- Standard rack width (483mm/19").
- 11mm/.43" flanges on top and bottom for extra strength.
- Durable black textured finish resists marks and scratches.
- Fits single rack space (44.5mm/1.75").

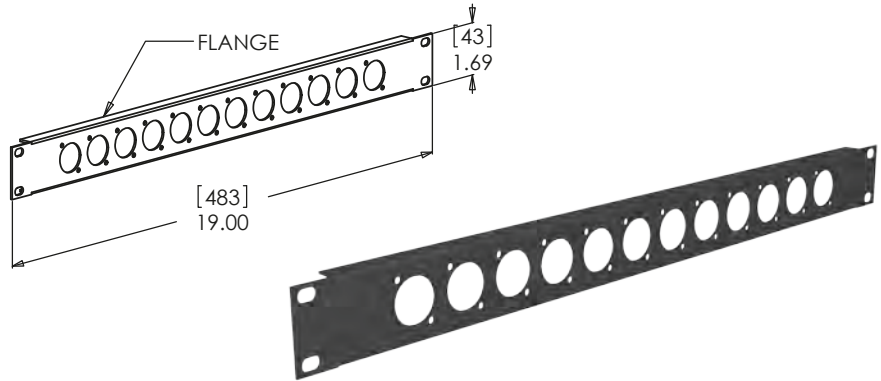

506-8721900

1 Space Horizontal Slot Vent Panel

Mat: Steel | Finish: Black | Wt: .29kg / .64lbs

- Pre-punched with horizontal slots to allow air to circulate.
- For rack enclosures where heat build up is a concern.
- Made from heavy duty steel (1.5mm/16ga).
- Standard rack width (483mm/19").
- 11mm/.43" flanges on top and bottom for extra strength.
- Durable black textured finish resists marks and scratches.

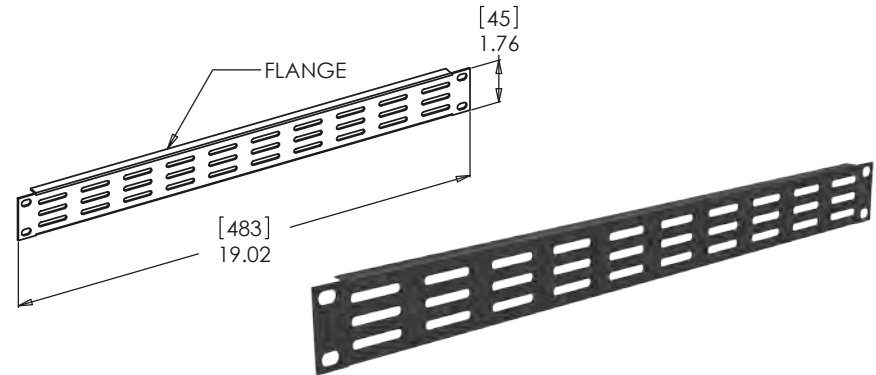

506-8722900

2 Space Horizontal Slot Vent Panel

Mat: Steel | Finish: Black | Wt: .47kg / 1.04lbs

- Pre-punched with horizontal slots to allow air to circulate.
- For rack enclosures where heat build up is a concern.
- Made from heavy duty steel (1.5mm/16ga).
- Standard rack width (483mm/19").
- 11mm/.43" flanges on top and bottom for extra strength.
- Durable black textured finish resists marks and scratches.

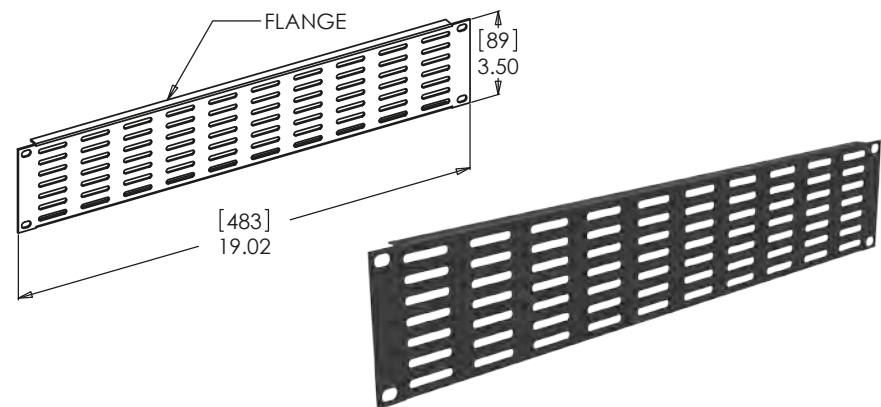

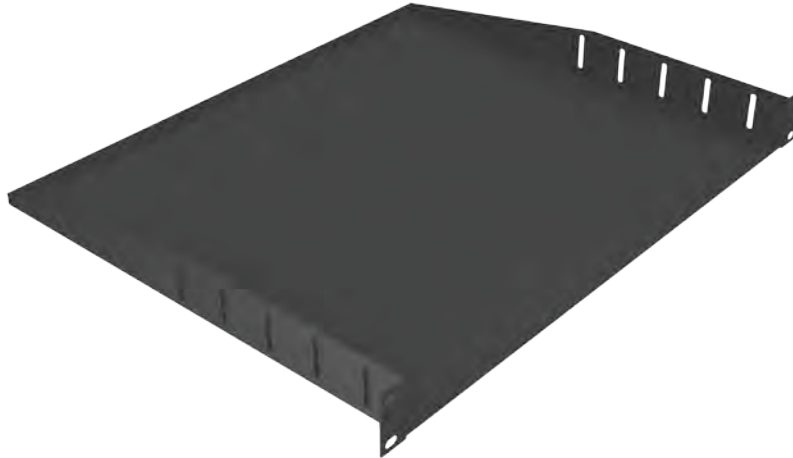
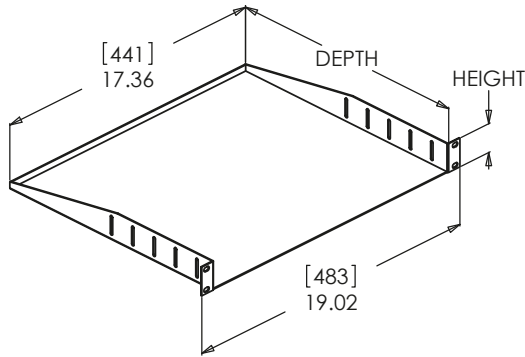

506-9031900

Utility Shelf - 1 Rack Space

Mat: Steel | Finish: Black | Wt: 2.14kg / 4.63lbs

- 1-3/4" Height, 14.97" Depth

506-9032900

Utility Shelf - 2 Rack Space

Mat: Steel | Finish: Black | Wt: 2.40kg / 5.29lbs

- 3-1/2" Height, 14.97" Depth

506-9033900

Utility Shelf - 3 Rack Space

Mat: Steel | Finish: Black | Wt: 3.60kg / 7.94lbs

- 5-1/4" Height, 14.97" Depth

506-9034900

Utility Shelf - 4 Rack Space

Mat: Steel | Finish: Black | Wt: 4.50kg / 9.92lbs

- 7" Height, 16" Depth
- Provides a quick and easy method for rack mounting equipment that cannot normally be mounted in a rack.
- Made from heavy duty steel (1.5mm/16ga).
- One-piece construction for maximum strength.
- Durable black textured finish resists marks and scratches.

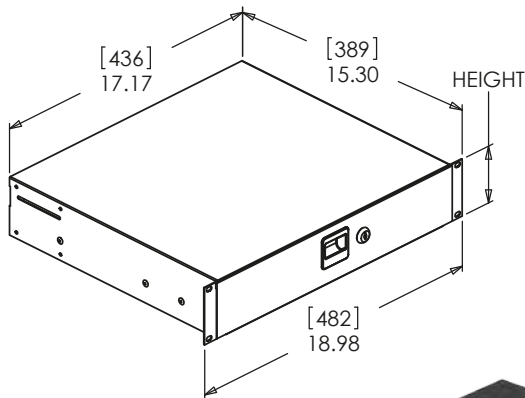

506-9052900

Sliding Drawer - 2 Rack Space

Mat: Steel | Finish: Black | Wt: 6.60kg / 14.55lbs

- 3-1/2" Height

506-9053900

Sliding Drawer - 3 Rack Space

Mat: Steel | Finish: Black | Wt: 7.40kg / 16.31lbs

- 5-1/4" Height

506-9054900

Sliding Drawer - 4 Rack Space

Mat: Steel | Finish: Black | Wt: 8.30kg / 18.30lbs

- 7" Height
- 16ga chassis with 14ga front panel.
- Fully enclosed top prevents contents from spilling out and debris from getting in.
- Flush mount spring loaded latch prevents unnecessary opening of the drawer.
- Lock and keys included.
- Drawer extends to a full 356mm/14" for easy access.
- High quality ball bearing slides with release mechanism.
- Durable black textured finish resists marks and scratches.

506-9041900

Single Space Sliding Shelf/Drawer

Mat: Steel | Finish: Black | Wt: 3.30kg / 7.28lbs

- Made from heavy duty steel (1.5mm/16ga).
- High quality ball bearing slides with release mechanism.
- Sliding rear brackets provide full support even when the shelf is fully extended.
- Two latches prevent unnecessary extension of drawer.
- Drawer extends a full 356mm/14".
- Durable black textured finish resists marks and scratches.

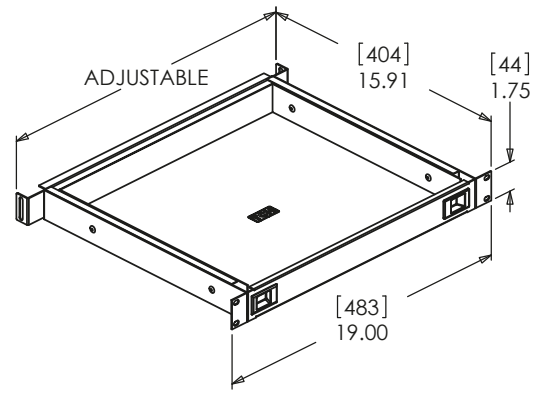
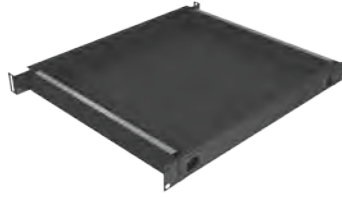

506-2245900

Full Hole Pre-Tapped Rack Rail

Mat: Steel | Finish: Black | Wt: 2.43kg / 5.36lbs

- Made from heavy duty steel (3mm/11ga).
- 2000mm/78.75" length (45 rack spaces).
- Pre-tapped with 10-32 holes for mounting equipment.
- Uses 10-32 quadrex 3/4" length machine screw, TCH part 512-6007900.
- Pre-punched with 5.4mm/.21" and 6.7mm/.265" holes for side rack mounting.
- Durable black textured finish resists marks and scratches.

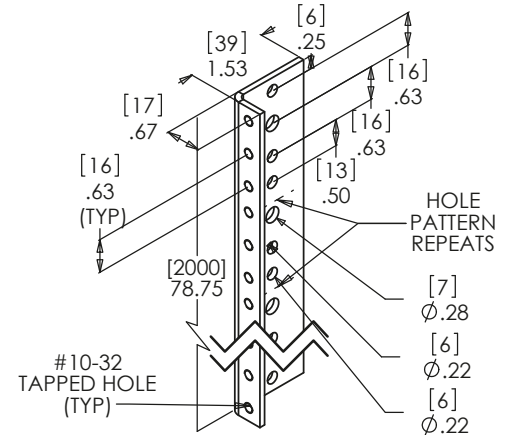

506-2248900

Combination Rack Rail

Mat: Steel | Finish: Black | Wt: 2.22kg / 4.89lbs

- Made from heavy duty 2.5mm/12ga steel.
- 1956mm/77" length (44 rack spaces).
- Pre-punched 7.1mm/.28" holes on front and side of rail for easy mounting of equipment using captive nuts 506-2251900.
- Full hole spacing with conveniently spaced punched, slotted holes for mounting rails to the sides of the rack.
- Durable black textured finish resists marks and scratches.

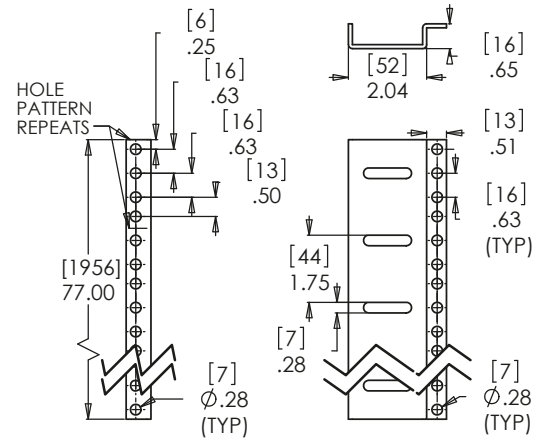

506-2251900

Captive Nut

Mat: Steel | Finish: Black | Wt: .005kg / .01lbs

- 10-32 Captive nut for use on 506-2248900 rack rail.

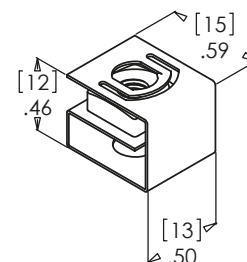

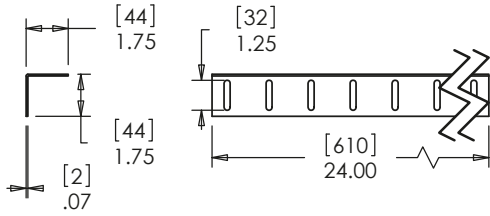

506-2252900

Heavy Duty Support Rack Rail

Mat: Steel | Finish: Black | Wt: .68kg / .15lbs

- Provides maximum support for heavy equipment.
- Conveniently spaced for mounting to 506-2248900 combination rail.
- Heavy duty steel (2mm/14ga.)
- 610mm/24" length but can be cut to a shorter length using a standard hack saw.
- Durable black finish.
- Ideal for power amps, VCR's, and monitor installations.

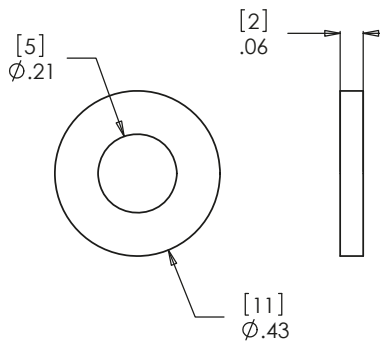

506-2250900

Black Plastic Washer

Mat: Plastic | Finish: Black | Wt: .005kg / .01lbs

- Black plastic washer with .21" hole size.

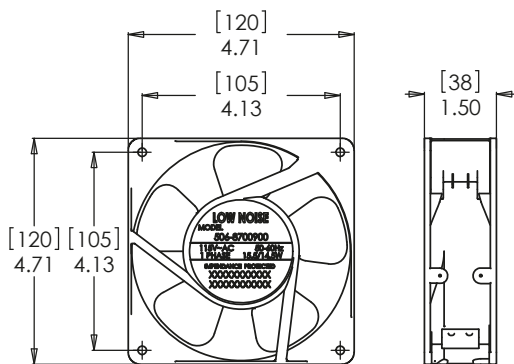

506-8700900

Low Noise Five Blade Cooling Fan

Mat: Steel/Plastic | Finish: Black | Wt: .52kg / 1.15lbs

- For use in equipment racks and other applications.
- 95 CFM (cubic feet per minute).
- 190mA / 13W / 115V.
- Ball bearing construction.
- Five blades.
- Low Noise.

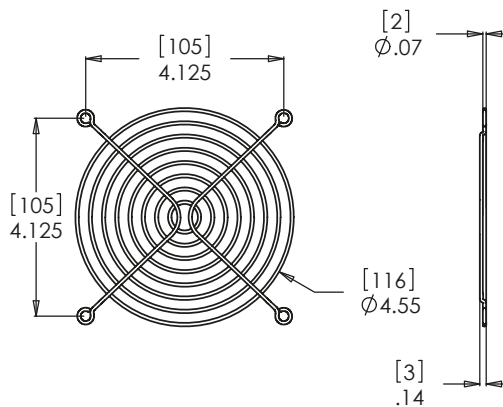

506-8740800

Finger Guard

Mat: Steel | Finish: Zinc Plate | Wt: .04kg / .09lbs

- Steel grill helps prevent fan blade accidents to fingers.
- Mounts externally over fan.

506-4001900

4" Round Access Port

Mat: Plastic | Finish: Black | Wt: .12kg / .26lbs

- Quick access ideal for running power cords through the back of racks or as a vent port.
- Outside Diameter: 6"
- Inside Diameter: 4.25"
- UV resistant.
- Water tight seal.
- Quick and simple installation reduces labor costs.
- Compact design for mounting in smaller racks.
- Lid can be tethered to case using 514-2126852 wire lid stay.

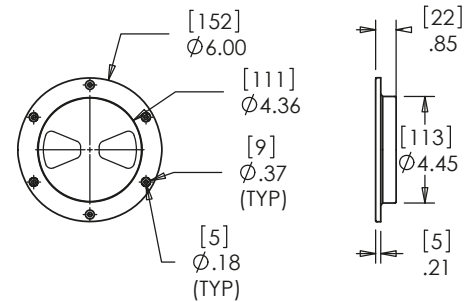

506-5001900

Rectangular Access Door

Mat: Plastic | Finish: Black | Wt: 1.01kg / 2.22lbs

- Hinged lid and frame provides quick and easy access to case interiors.
- Dimensions: 10.75" x 15" x 1.5".
- UV resistant.
- Water tight seal.
- Mounting fasteners are hidden when door is closed.
- Door is removable.
- Can be mounted in horizontal or vertical position.
- Impact resistant glass filled polypropylene.
- Cam style latch.

