

BUMPER-GLIDE-DOME-DIMPLE-STEEL-PLASTIC-RUBBER-STEEL INSERT-ROUND-TALL-OVAL-TILT

FEET

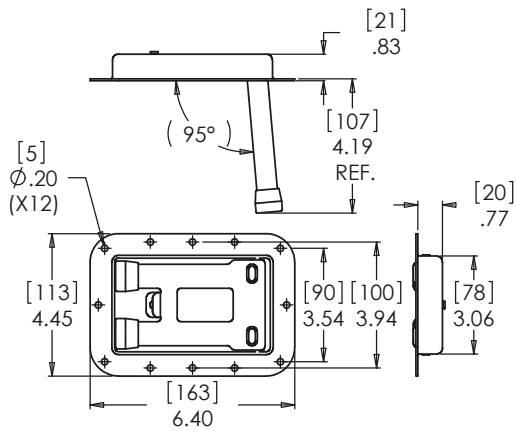
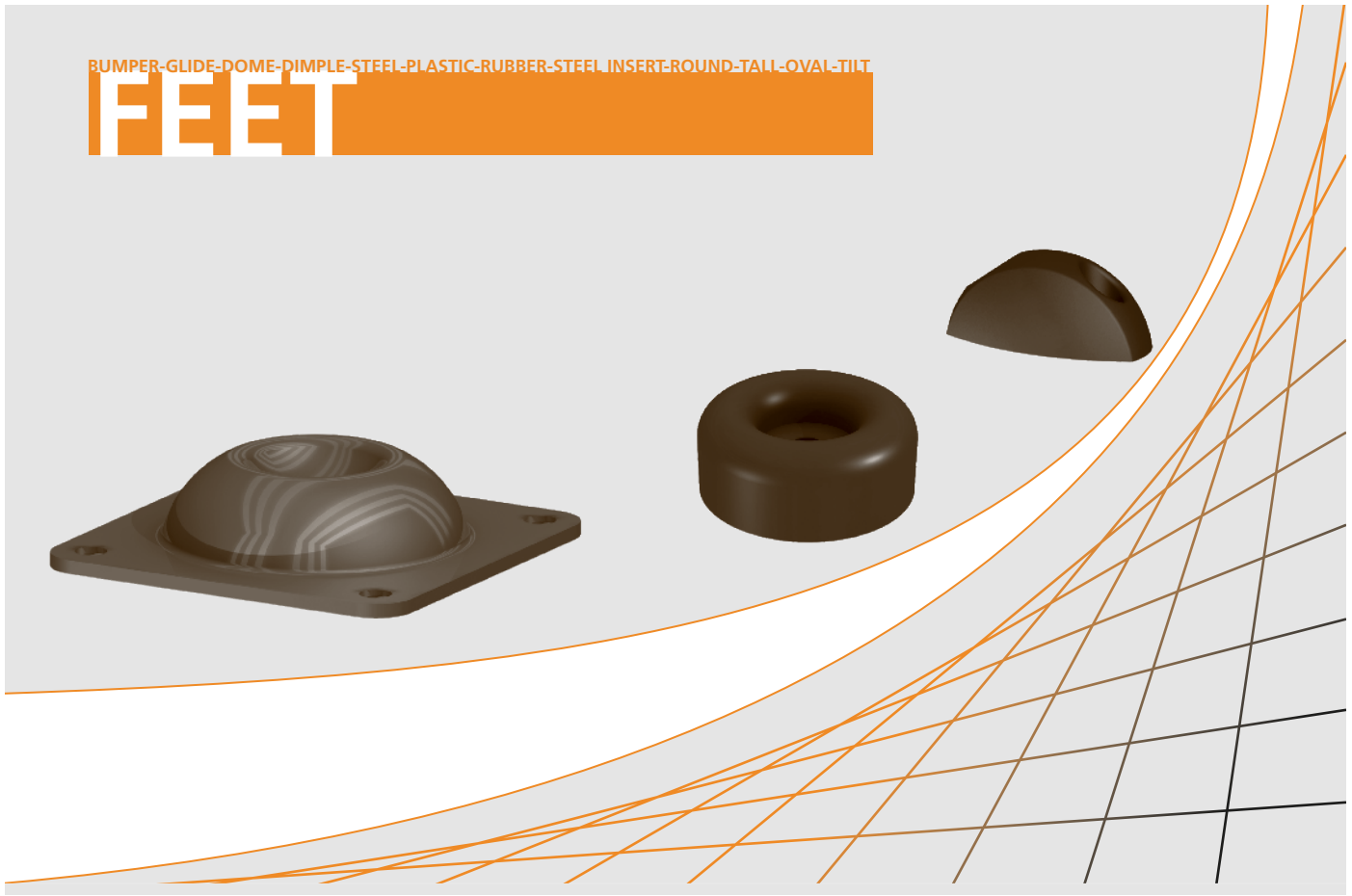

503-157090
Recessed Retractable Tilt Foot

Mat: Steel | Finish: Zinc Plate | Wt: .02kg / .04lbs

- Fold out leg has two rubber foot covers for grip and floor protection.
- Spring loaded mechanism keeps foot extended.
- Latch mechanism holds foot in place when not in use.
- Ideal for amplifiers and speakers.

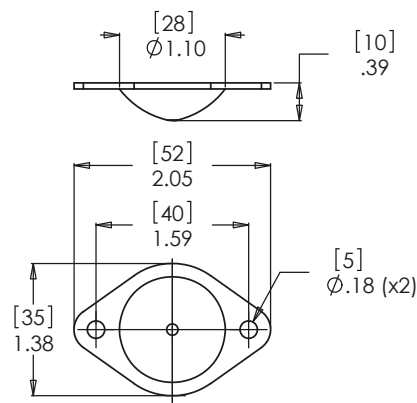

503-1514800
Two-Hole Deep Bottom Knob

Mat: Steel | Finish: Zinc Plate | Wt: .02kg / .04lbs

- Industry standard bottom knob.
- Deep recess helps to protect application from floor surface.
- For use on molded plastic, wood, laminates, or carpet covered applications.
- Only two mounting holes.

503-1530800

Heavy Duty Steel Stacking Foot

Mat: Steel | Finish: Zinc Plate | Wt: .08kg / .18lbs

- Heavy duty - For use on applications where rugged hardware is needed.
- Foot height of .57"
- Mates securely with the 503-1531800 when stacking is required.

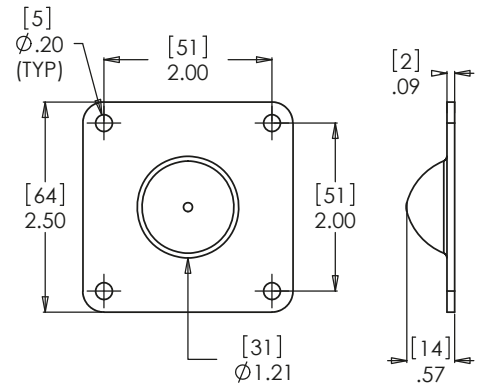

503-1531800

Heavy Duty Steel Stacking Cup

Mat: Steel | Finish: Zinc Plate | Wt: .09kg / .20lbs

- Heavy duty - For use on applications where rugged hardware is needed.
- Recess depth of .59"
- Can also be used as a foot.
- Mates securely with the 503-1530800 when stacking is required.

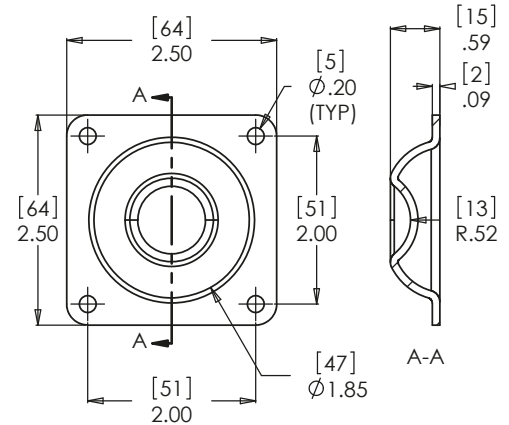

503-1614900

Domed Foot

Mat: Plastic | Finish: Black | Wt: .05kg / .11lbs

- For use as a leveling foot in conjunction with the 511-2293800 and 511-2294800 casters.
- Curved shape allows for foot to deflect impacts.
- Made from ultra durable high density plastic.
- Can be used as a glide for enclosures that regularly slide against the wall.

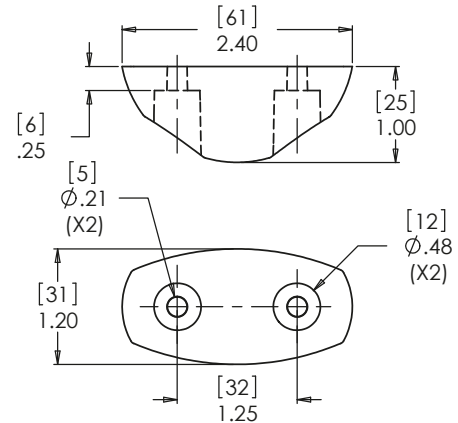

503-1601900

Rubber Foot

Mat: Rubber | Finish: Black | Wt: .01kg / .02lbs

- .38" high rubber foot.
- Great for small cases and speaker boxes.

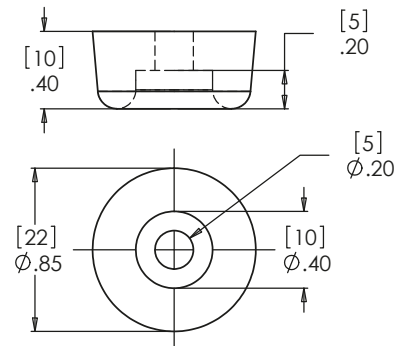
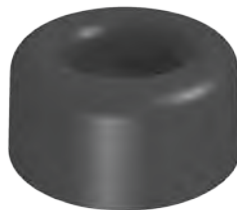

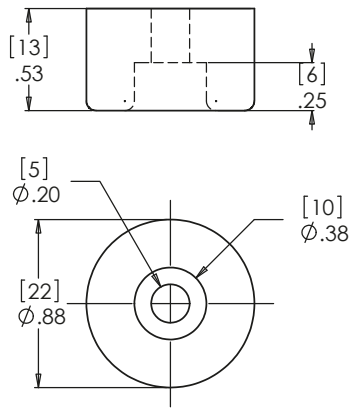

503-160390

Small Rubber Foot

Mat: Rubber | Finish: Black | Wt: .01kg / .02lbs

- Rubber composition helps stop sliding of enclosures.
- Steel insert for extra fixing strength.
- .53" high.
- For medium duty applications.
- Protects the underside of enclosures and surfaces on which the enclosure is placed.

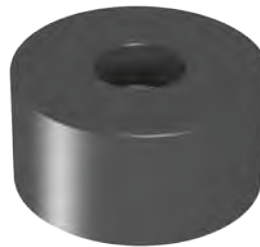
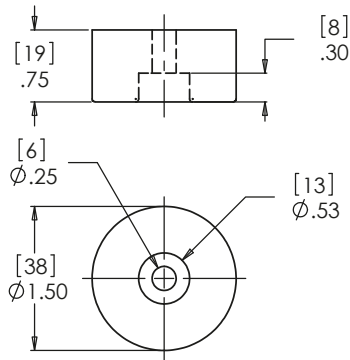

503-160690

Medium Rubber Foot

Mat: Rubber | Finish: Black | Wt: .04kg / .09lbs

- Rubber composition helps stop sliding of enclosures.
- Steel insert for extra fixing strength.
- .75" high for increased shock absorption and wearability.
- Protects the underside of enclosures and surfaces on which the enclosure is placed.

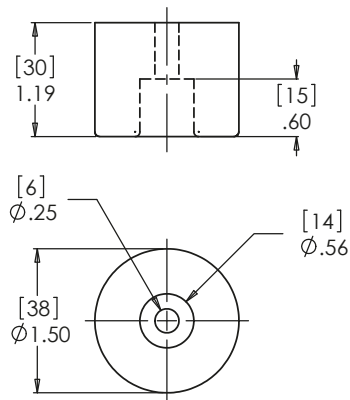

503-160590

Tall Rubber Foot

Mat: Rubber/Steel | Finish: Black | Wt: .05kg / .11lbs

- Rubber composition helps stop sliding of enclosures.
- Steel insert for extra mounting strength.
- 1.19" high for increased shock absorption and wearability.
- Protects the underside of enclosures and surfaces on which the enclosure is placed.

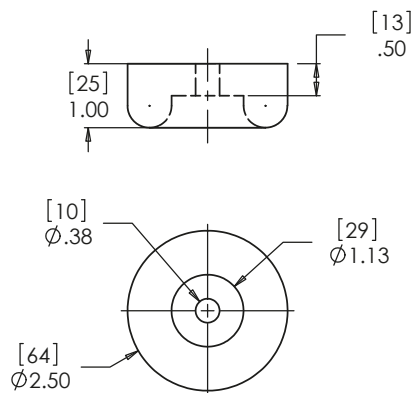

503-160890

Large Rubber Foot

Mat: Rubber | Finish: Black | Wt: .11kg / .24lbs

- Over sized rubber foot for heavy duty applications.
- Rubber composition helps stop sliding of enclosures.
- 1" high for increased shock absorption and wearability.
- Protects the underside of enclosures and surfaces on which the enclosure is placed.

Notes

A series of horizontal dotted lines for taking notes, starting below the 'Notes' header and extending to the bottom of the page.